

# Pulsar EX

700 / 1000 / 1500

**DIREKTRONIK**

e-mail: [info@direktronik.se](mailto:info@direktronik.se)  
tel: 08-52 400 700 fax: 08-520 18121

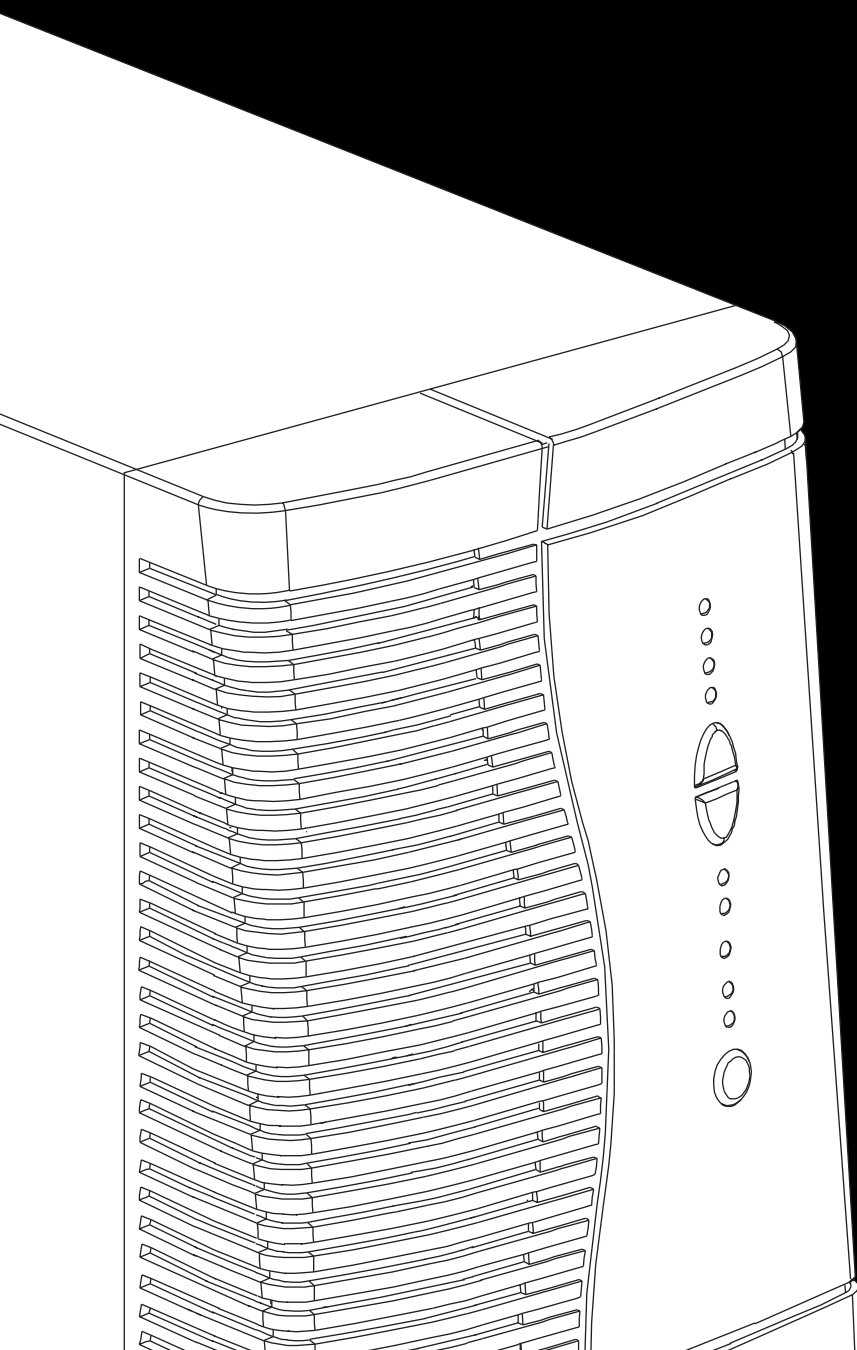

**M G E**  
UPS SYSTEMS



# Introduction

Thank you for selecting an MGE UPS SYSTEMS product to protect your electrical equipment.

The **Pulsar EX** range has been designed with the utmost care. We recommend that you take the time to read this manual to take full advantage of the many features of your UPS.

MGE UPS SYSTEMS pays great attention to the environmental impact of its products. Measures that have made **Pulsar EX** a reference in environmental protection include:

- ▶ the eco-design approach used in product development;
- ▶ recycling of **Pulsar EX** at the end of its service life.

To discover the entire range of MGE UPS SYSTEMS products and the options available for the **Pulsar EX** range, we invite you to visit our web site at [www.mgeups.com](http://www.mgeups.com) or contact your MGE UPS SYSTEMS representative.

## Safety rules

### Safety of persons

A UPS has its own internal power source (the battery). Consequently, the power outlets may be energised even if the UPS is disconnected from the AC-power source.



**Dangerous voltage levels are present within the UPS. It should be opened exclusively by qualified service personnel.**

**The UPS must be properly earthed. Measurements are required to ensure that the total leakage current of the UPS and the protected equipment does not exceed 3.5 mA.**

**The battery supplied with the UPS contains small amounts of toxic materials. To avoid accidents, the directives listed below must be observed:**

- ▶ **Never burn the battery (risk of explosion).**
- ▶ **Do not attempt to open the battery (the electrolyte is dangerous for the eyes and skin).**
- ▶ **Comply with all applicable regulations for the disposal of the battery.**
- ▶ **Batteries constitute a danger (electrical shock, burns). The short-circuit current may be very high. Precautions must be taken for all handling.**

### Product safety

UPSs must be connected to a nearby wall outlet that is easily accessible.

The UPS can be disconnected from the AC-power source by removing the power cord.

- ▶ **Never install the UPS near liquids or in an excessively damp environment.**
- ▶ **Never let a foreign body penetrate inside the UPS.**
- ▶ **Never block the ventilation grates of the UPS.**
- ▶ **Never expose the UPS to direct sunlight or a source of heat.**

### Special precautions

The UPS connection instructions contained in this manual must be followed in the indicated order.

Check that the indications on the rating plate correspond to your AC-power system and to the actual electrical consumption of all the equipment to be connected to the UPS.

If the UPS must be stored prior to installation, storage must be in a dry place.

The admissible storage temperature range is -20° C to +45° C.

If the UPS remains de-energised for a long period, we recommend that you energise the UPS for a period of 24 hours, at least once every month. This charges the battery, thus avoiding possible irreversible damage.

Prior to handling the battery:

- ▶ **remove all watches, rings, bracelets and any other metal objects;**
- ▶ **use tools with insulated handles.**

# Foreword

## Using this document

Information may be found primarily by consulting:

- ▶ the contents,
- ▶ the index.

## Pictograms



Important instructions that must always be followed.



Information, advice, help.



Visual indication.



Action.



Audio indication.

In the illustrations on the following pages, the symbols below are used:



LED off.



LED on.



LED flashing.

|   |           |
|---|-----------|
| <b>1. Presentation</b>  |           |
| <b>1.1 Pulsar EX range</b> .....  | <b>7</b>  |
| Tower model .....   | 7         |
| Rack model .....  | 7         |
| <b>1.2 Back</b> .....   | <b>8</b>  |
| Tower model .....   | 8         |
| Rack model .....  | 9         |
| <b>1.3 Control panel</b> .....  | <b>10</b> |
| <b>2. Installation</b>  |           |
| <b>2.1 Unpacking and checks</b> .....   | <b>11</b> |
| Tower model .....   | 11        |
| Rack model .....  | 12        |
| <b>2.2 Installation of the rack version</b> .....                                 | <b>13</b> |
| <b>2.3 Connection to the RS 232 or USB communications port (optional)</b> .....   | <b>14</b> |
| <b>2.4 Installation of the communications-card option</b> .....                   | <b>15</b> |
| Tower model .....   | 15        |
| Rack model .....  | 15        |
| <b>2.5 Connections</b> .....  | <b>16</b> |
| Tower model .....   | 16        |
| Rack model .....  | 16        |
| <b>3. Operation</b>   |           |
| <b>3.1 Start-up</b> .....   | <b>17</b> |
| <b>3.2 Bargraph indications</b> .....   | <b>17</b> |
| <b>3.3 Operation on battery power (following failure of AC input power)</b> ..... | <b>18</b> |
| Transfer to battery power .....   | 18        |
| Threshold for the low-battery warning .....                                       | 18        |
| End of backup time .....  | 18        |
| Sleep mode .....  | 18        |



# Contents

|  |           |
|--|-----------|
| <b>3.4 Personalisation (optional)</b> .....        | <b>19</b> |
| Function .....                                     | 19        |
| "ON / OFF conditions" tab .....                    | 19        |
| "Battery" tab .....                                | 19        |
| "Output" tab .....                                 | 20        |
| "Bypass" tab .....                                 | 20        |
| <b>3.5 Shutdown</b> .....                          | <b>20</b> |
| <b>4. Maintenance</b>                              |           |
| <b>4.1 Troubleshooting</b> .....                   | <b>21</b> |
| <b>4.2 Replacement of the battery module</b> ..... | <b>22</b> |
| Tower model .....                                  | 22        |
| Rack model .....                                   | 23        |
| <b>5. Environment</b> .....                        | <b>24</b> |
| <b>6. Appendices</b>                               |           |
| <b>6.1 Technical characteristics</b> .....         | <b>25</b> |
| Simplified diagram .....                           | 25        |
| Operating conditions .....                         | 25        |
| <b>6.2 Glossary</b> .....                          | <b>26</b> |
| <b>6.3 Index</b> .....                             | <b>27</b> |

# 1. Presentation

## 1.1 Pulsar EX range

### Tower model

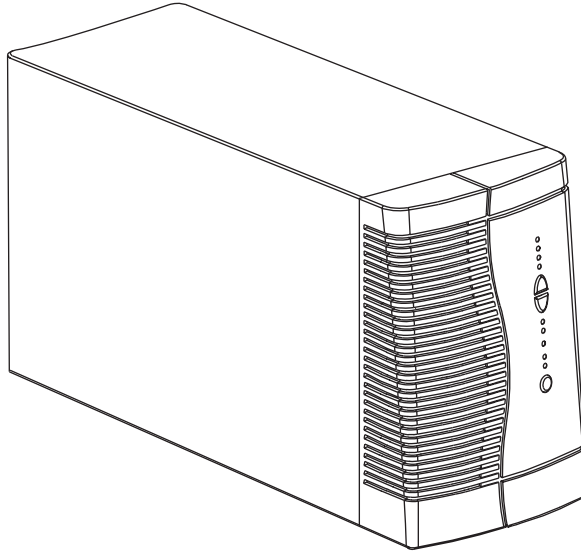

|                         | Dimensions in mm<br>(H x W x D) |
|-------------------------|---------------------------------|
| <b>EX 700 / EX 1000</b> | 235.5 x 145 x 400               |
| <b>EX 1500</b>          | 235.5 x 145 x 505               |

|                | Weight in kg |
|----------------|--------------|
| <b>EX 700</b>  | 10           |
| <b>EX 1000</b> | 12           |
| <b>EX 1500</b> | 15           |

### Rack model

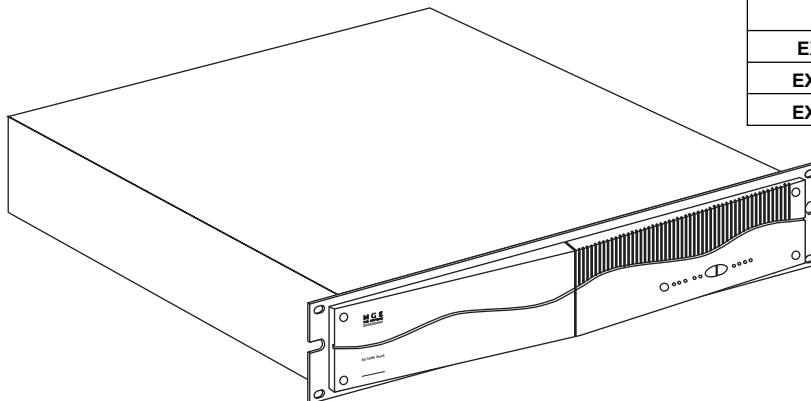

|                     | Dimensions in mm<br>(H x W x D) |
|---------------------|---------------------------------|
| <b>EX 700 Rack</b>  | 88 (2U) x 482.6 x 430           |
| <b>EX 1000 Rack</b> | 88 (2U) x 482.6 x 430           |
| <b>EX 1500 Rack</b> | 88 (2U) x 482.6 x 493           |

|                     | Weight in kg |
|---------------------|--------------|
| <b>EX 700 Rack</b>  | 14           |
| <b>EX 1000 Rack</b> | 16           |
| <b>EX 1500 Rack</b> | 20           |

# 1. Presentation

## 1.2 Back

### Tower model

Pulsar EX 700 / Pulsar EX 1000

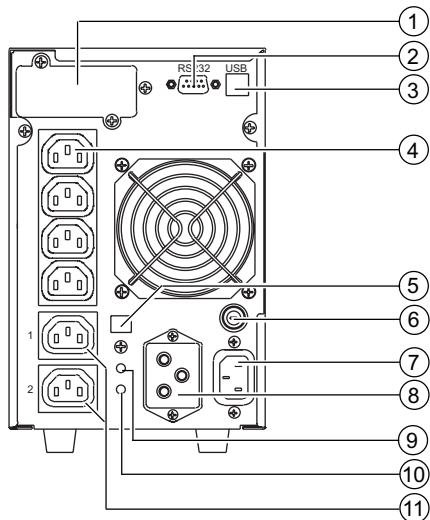

Pulsar EX 1500

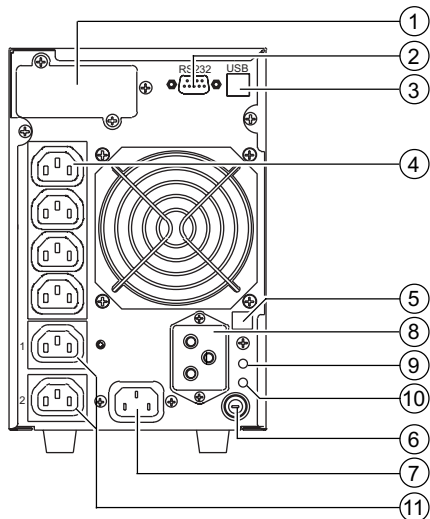

- ① slot for communications-card option.
- ② RS232 communications port.
- ③ USB communications port.
- ④ four outlets for direct connection of protected equipment.
- ⑤ connector for automatic detection of an additional battery module.
- ⑥ input circuit breaker.
- ⑦ socket for connection to AC-power source.
- ⑧ connector for an additional battery module.
- ⑨ pushbutton to test phase/neutral inversion of AC-power source.
- ⑩ LED indicating phase/neutral inversion of AC-power source.
- ⑪ two programmable outlets (outlet 1 and 2).



# 1. Presentation

## Rack model

### Pulsar EX 700 Rack / Pulsar EX 1000 Rack / Pulsar EX 1500 Rack

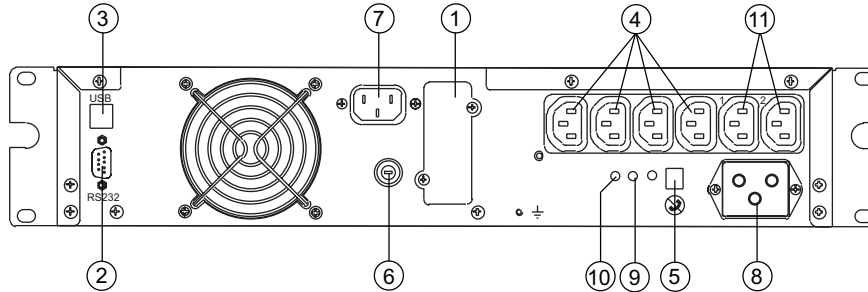

- ① slot for communications-card option.
- ② RS232 communications port.
- ③ USB communications port.
- ④ four outlets for direct connection of protected equipment.
- ⑤ connector for automatic detection of an additional battery module.
- ⑥ input circuit breaker.
- ⑦ socket for connection to AC-power source.
- ⑧ connector for an additional battery module.
- ⑨ pushbutton to test phase/neutral inversion of AC-power source.
- ⑩ LED indicating phase/neutral inversion of AC-power source.
- ⑪ two programmable outlets (outlet 1 and 2).

# 1. Presentation

## 1.3 Control panel

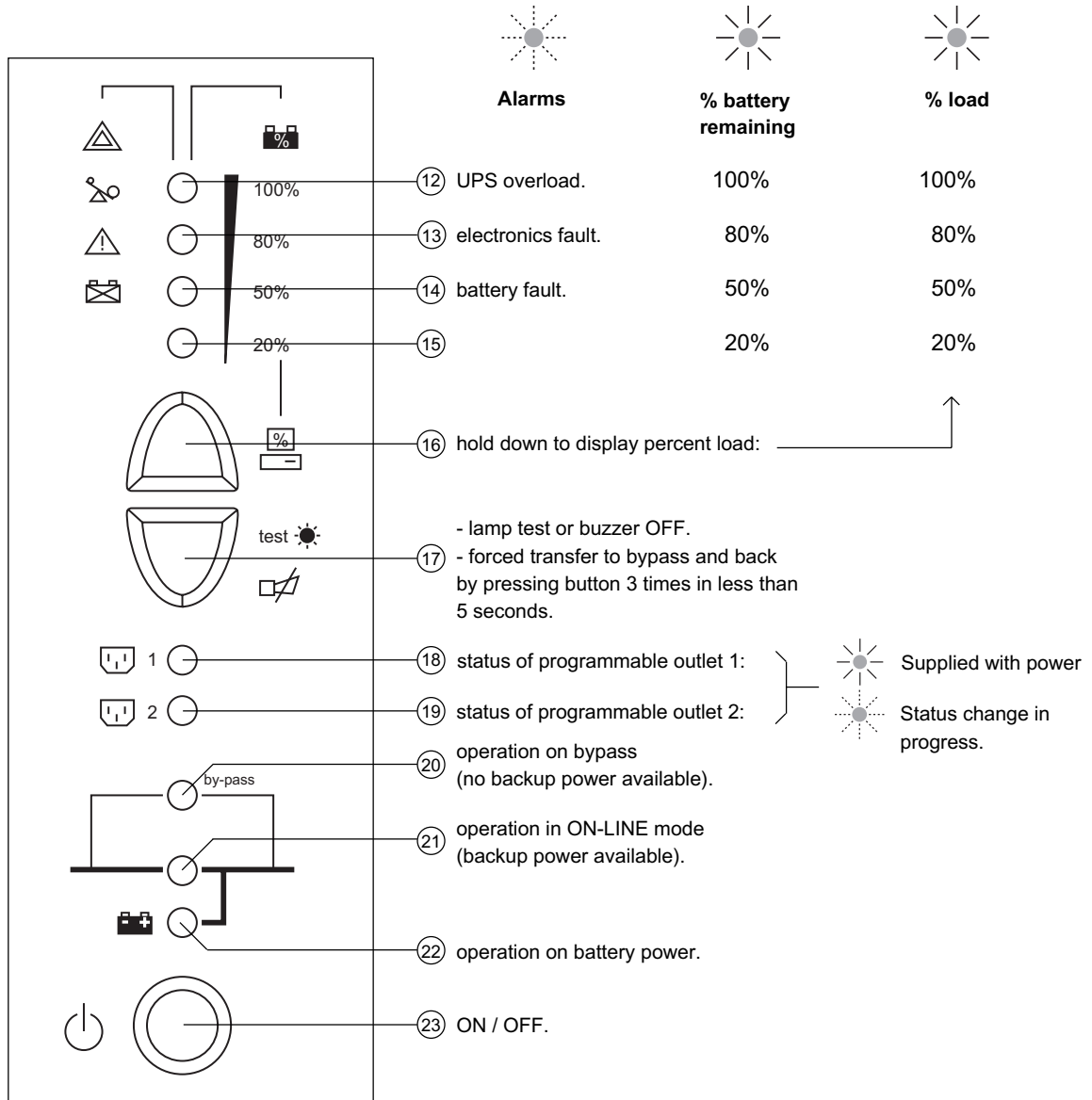

## 2. Installation

### 2.1 Unpacking and checks

#### Tower model

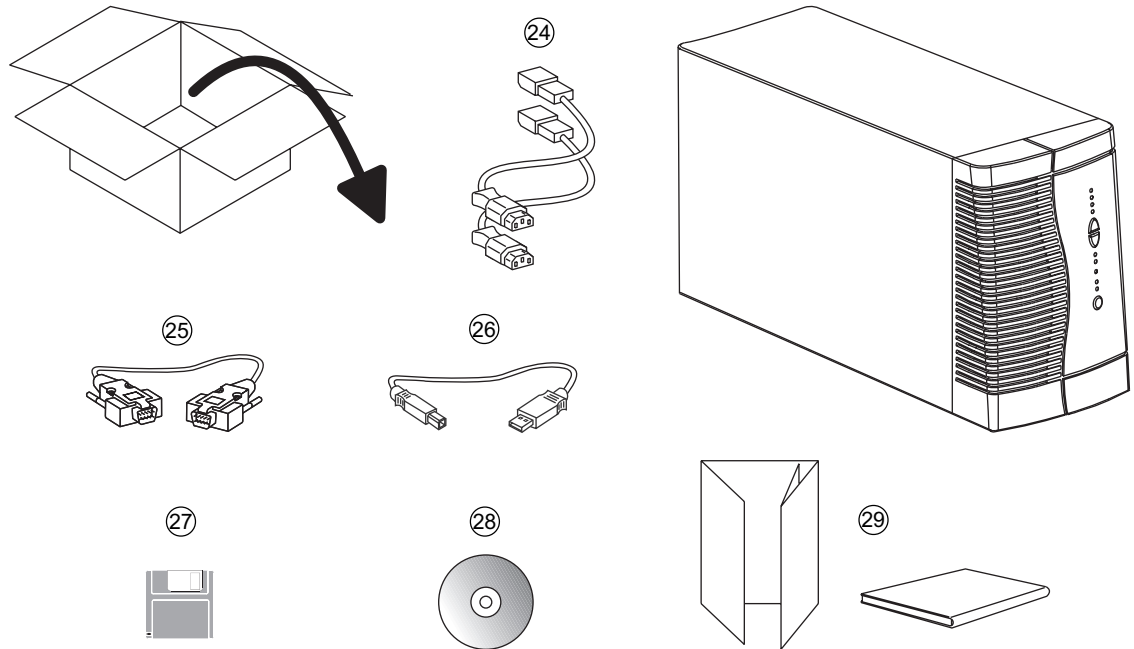

(24) two cords for connection of the protected equipment.

(25) RS 232 communications cable.

(26) USB communications cable.

(27) "UPS Driver" diskette for UPS personalisation.

(28) "Solution Pac" CD ROM.

(29) documentation.

## 2. Installation

### Rack model

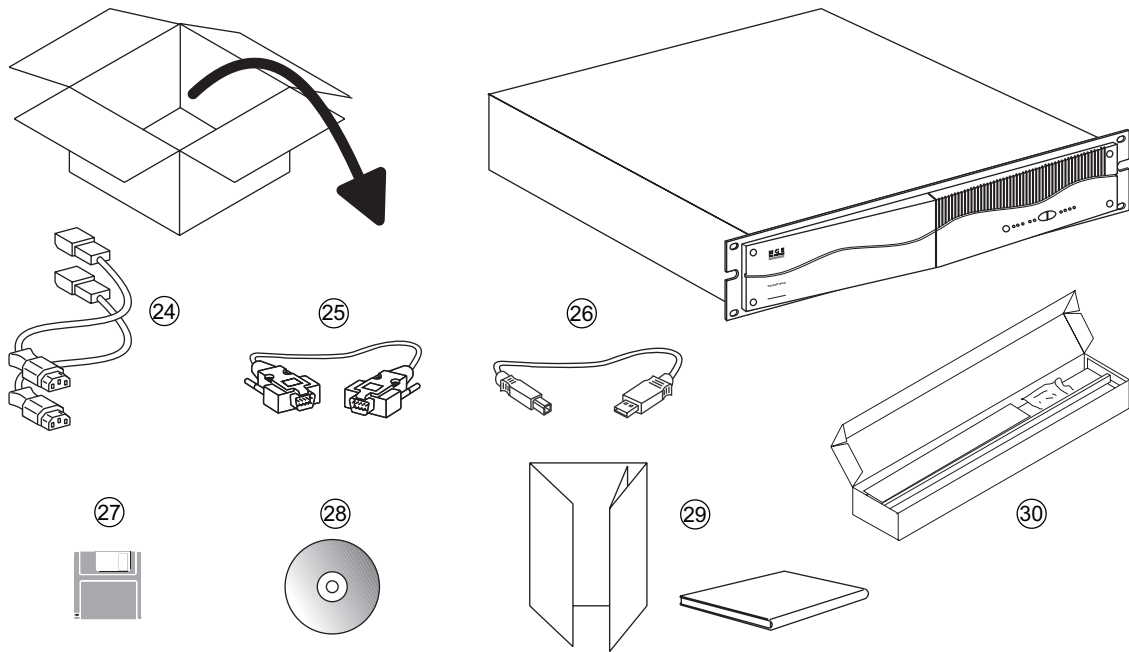

- ②④ two cords for connection of the protected equipment.
- ②⑤ RS 232 communications cable.
- ②⑥ USB communications cable.
- ②⑦ "UPS Driver" diskette for UPS personalisation.
- ②⑧ "Solution Pac" CD ROM.
- ②⑨ documentation.
- ③⑩ telescopic rails for mounting in 19" bay with mounting hardware.

## 2. Installation

### 2.2 Installation of the rack version

Rack mounting diagram with rails.

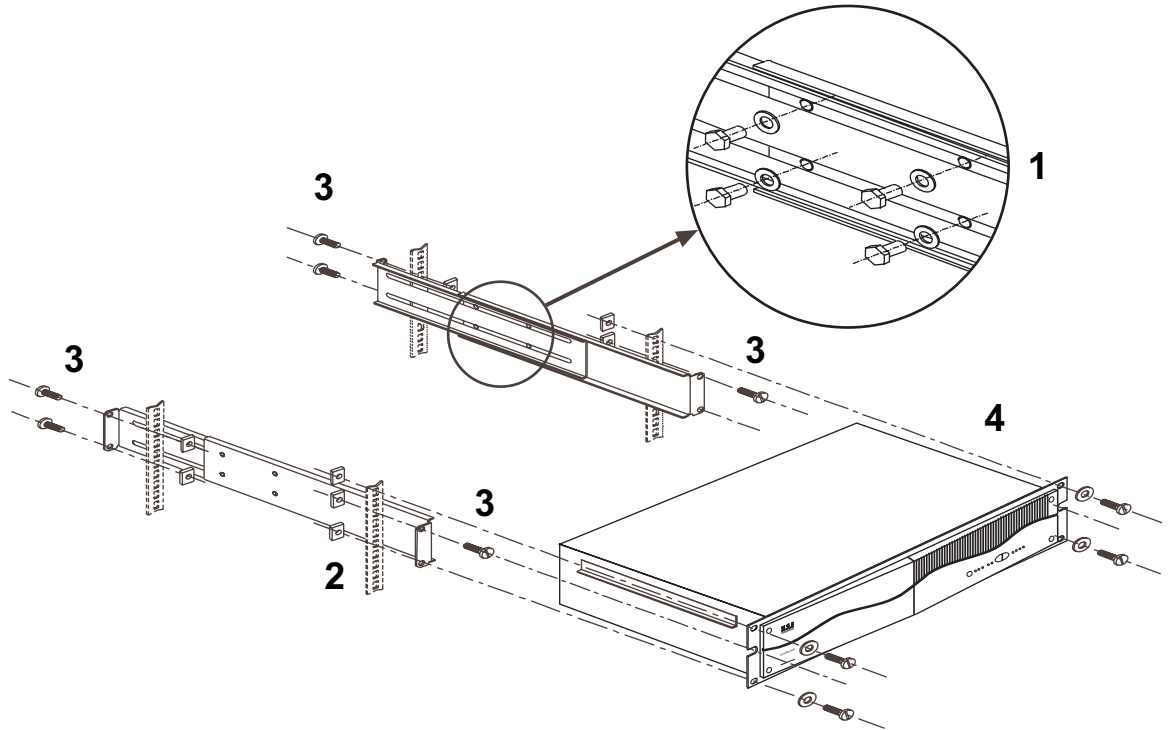

The rails and the necessary mounting hardware are supplied by MGE UPS SYSTEMS.

## 2. Installation

### 2.3 Connection to the RS 232 or USB communications port (optional)

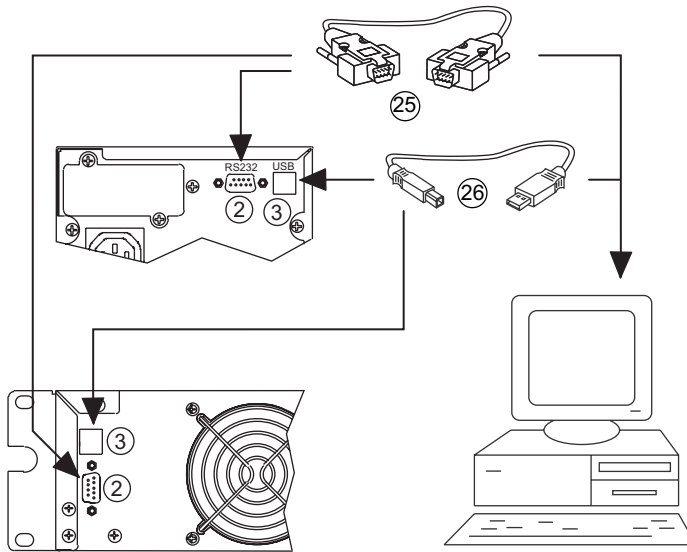

1 - Connect the RS 232 (25) or USB (26) communications cable to the serial port or the USB port on the computer.

2 - Connect the other end of the communications cable (25) or (26) to the RS 232 (2) or USB (3) communications port on the UPS.

The UPS can now communicate with all MGE UPS SYSTEMS supervision, set-up or safety software.



The RS 232 and USB communications ports cannot operate simultaneously.

## 2. Installation

### 2.4 Installation of the communications-card option

#### Tower model

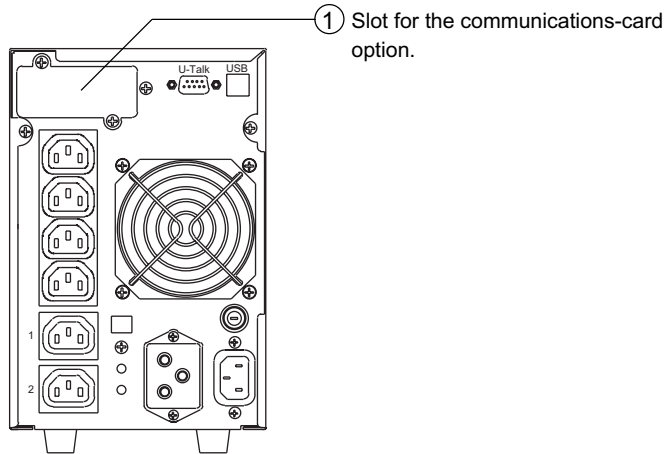

It is not necessary to shut down the UPS to install the communications card:

- 1 - Remove the slot ① cover secured by two screws.
- 2 - Insert the card in the slot.
- 3 - Secure the card with the two screws.

#### Rack model

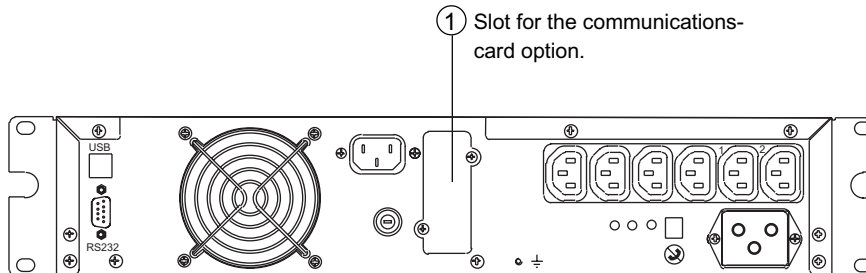

## 2. Installation

### 2.5 Connections



Check that the indications on the rating plate on the back of the UPS correspond to your AC-power system and to the actual electrical consumption of all the equipment to be connected to the UPS.

#### Tower model

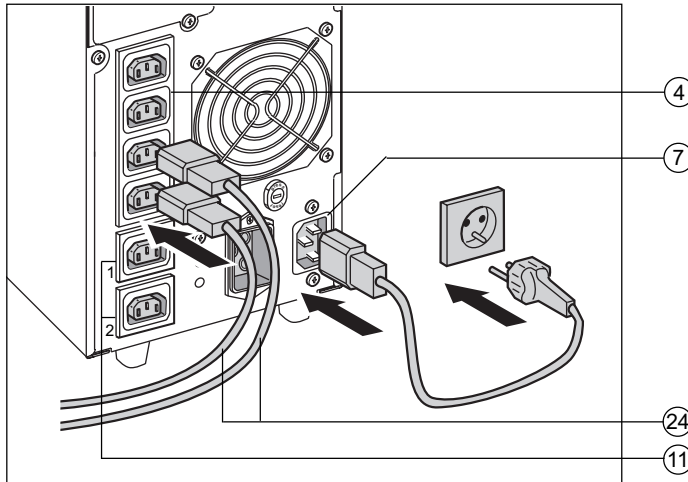



1 - Remove the power cord supplying the equipment to be protected. Check cord characteristics (> 250 V, 10 A, see the technical sheet).

2 - Connect the cord to the AC-power socket (7), then to the AC-power wall outlet.

3 - Connect the protected equipment to the UPS using the two cords (24). It is advised to connect priority loads to the four outlets (4) and any non-priority loads to the two programmable outlets (11) (If the UPS is connected to a computer running MGE communications software, it is possible to program the interruption of power to the two programmable outlets (11) during operation on battery power, thus reserving backup power for the priority loads).

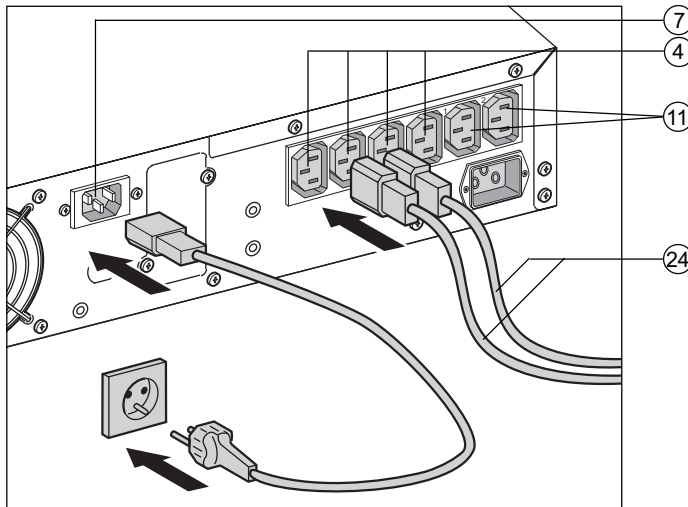
#### Rack model



 As soon as the UPS is energised, the battery begins charging. Eight hours are required to charge to the full rated backup time.



# 3. Operation

## 3.1 Start-up

The protected equipment connected to the UPS can be energised, whether AC input power is available or not.

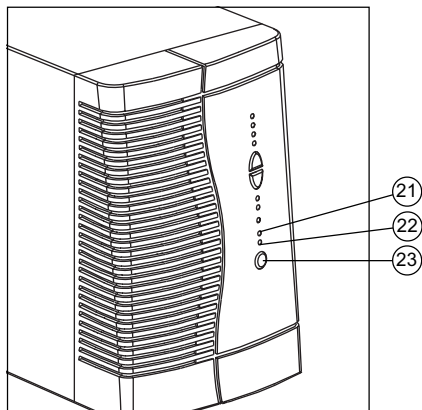

Press the ON / OFF button (23).

The buzzer beeps and all the LEDs go ON.

The buzzer beeps twice, then:

- If AC input power is available, LED (21) goes ON, indicating operation in ON-LINE mode.
- If AC input power is not available and the UPS is configured for automatic restart mode, the buzzer beeps three times and LED (22) goes ON, signalling operation on battery power.

**All connected equipment is energised.**



If LEDs (21) or (22) do not go ON or if LEDs (12) to (14) flash, there is a fault (see section 4.1).

## 3.2 Bargraph indications

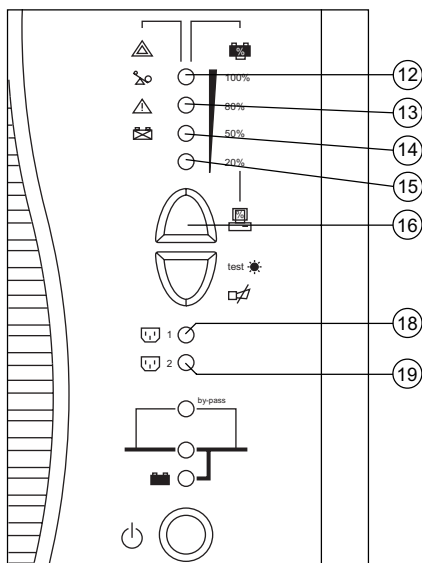

**LEDs (12) to (15) provide three different indications:**

- 1 - Remaining backup time in percent (during normal operation).
- 2 - Percent load drawn by the protected equipment, when button (16) is pressed.
- 3 - Operating faults (flashing LED and beeps):
  - (12) Overload.
  - (13) UPS fault.
  - (14) Battery fault.

**Status LEDs (18) and (19) for programmable outlets 1 and 2:**

- LEDs OFF: the outlets are not supplied with power.
  - LEDs flashing: status change in progress.
  - LEDs ON: the outlets are supplied with power.
- Outlets 1 and 2 can be remotely programmed and controlled. They may be used for sequential start-up of the protected applications, shedding of non-priority applications during operation on battery power, and priority management at the end of battery backup time to reserve the longest possible backup time for the most sensitive applications. These outlets are programmed using Solution Pac software.

## 3. Operation

### 3.3 Operation on battery power (following failure of AC input power)

#### Transfer to battery power

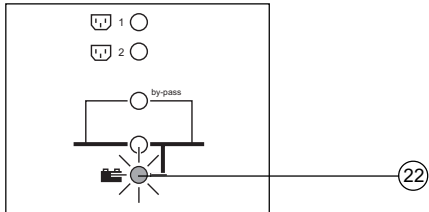

The AC-power source is outside tolerances, LED (23) is ON, the buzzer beeps three times.

**The equipment connected to the UPS is supplied by the battery.**

#### Threshold for the low-battery warning

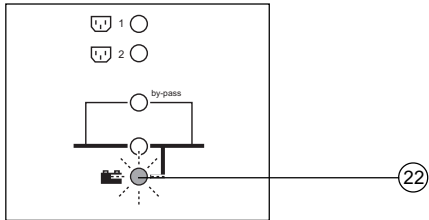

The low-battery warning threshold can be set by the user, with the "UPS Driver" software (see section 3.4).

LED (22) flashes.

The buzzer beeps every three seconds.

**There is very little remaining battery backup time. Close all applications because UPS automatic shutdown is imminent.**

#### End of backup time

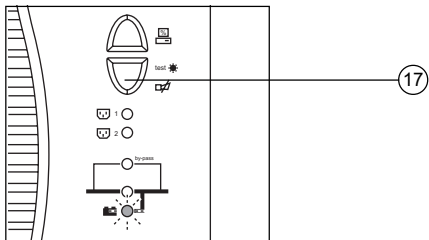

The buzzer sounds continuously.

Press button (17) to turn the buzzer OFF.

**The equipment is no longer supplied with power.**

#### Sleep mode

The UPS goes to sleep mode at the end of the battery backup time (LEDs (12) to (15) ON) until complete shutdown due to tripping of the battery-protection function against deep discharge.



**Return of AC input power:**

**If, in spite of the return of AC input power, the UPS does not restart, check that the automatic-restart function (activated by return of AC input power) has not been disabled (see section 3.4).**

## 3.4 Personalisation (optional)

### Function



Personalisation parameters can be set and modified using the "UPS Driver" software installed on a computer that is connected to the UPS (see section 2.3 Connection to the RS 232 (or USB) communications port).

**Check that the RS 232 (25) or USB (26) cable is properly connected.**

"UPS Driver" installation:

- 1 - Insert the "UPS Driver" diskette in the drive of a PC running Windows.
- 2 - Select the disk drive (A:).
- 3 - Double-click "upsdriv.exe".

Once "UPS Driver" has been installed, UPS parameters can be modified in a window containing a number of tabs, each presenting a set of parameters.

### "ON / OFF conditions" tab

| Personalisable function    | Default setting | Options  |
|----------------------------|-----------------|----------|
| Automatic start            | Enabled         | Disabled |
| Cold start (battery power) | Enabled         | Disabled |
| Forced shutdown            | Enabled         | Disabled |
| Sleep mode                 | Disabled        | Enabled  |
| UPS ON / OFF via software  | Enabled         | Disabled |

### "Battery" tab

| Personalisable function            | Default setting                   | Options                                |
|------------------------------------|-----------------------------------|--|
| Automatic "Battery test" intervals | Every day                         | Once a week<br>Once a month<br>No test |
| "Low-battery warning" threshold    | 20% remaining battery backup time | 40% remaining battery backup time      |

## 3. Operation

### "Output" tab

| Personalisable function                     | Default setting | Options                       |
|---|-----------------|-------------------------------|
| Rated UPS voltage                           | 230 V           | 200 V - 208 V - 220 V - 240 V |
| Rated UPS frequency                         | F = 50 Hz       | 60 Hz                         |
| UPS tolerance for AC-power source frequency | F ± 5%          | F ± 1% to ± 10%, in 1% steps  |
| Overload alarm threshold                    | 110%            | 0 to 110%, in 10% steps       |
| UPS restart following short-circuit         | Disabled        | Enabled (click to add check)  |

### "Bypass" tab

| Personalisable function  | Default setting | Options                          |
|--|-----------------|----------------------------------|
| Transfer to bypass if overload   | Enabled         | Disabled (click to remove check) |
| Transfer to bypass following a fault, whatever the conditions on the AC-power source | Disabled        | Enabled (click to add check)     |

## 3.5 Shutdown

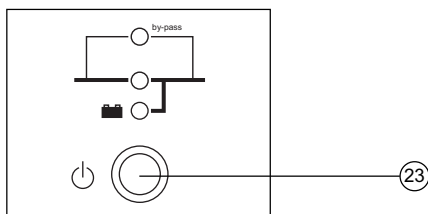

Press button 23 (return to the OFF position).

**The connected equipment is no longer supplied with power.**

## 4.1 Troubleshooting

If any of LEDs (12), (13) or (14) flash, there is a operating anomaly or an alarm.



If a LED flashes, the bargraph data is no longer displayed.

### Troubleshooting not requiring MGE UPS SYSTEMS after-sales support

| Indication                             | Signification   | Correction  |
|--|---|---|
| LED (12) flashes and the buzzer beeps. | <p>UPS overload. Overload is too long or too high. The buzzer sounds continuously.</p> <ul style="list-style-type: none"> <li>▶ If AC power is present and within tolerances, the UPS goes to bypass mode (supply directly by the AC-power source). LED (20) flashes.</li> <li>▶ If AC power is not present or not within tolerances, the connected applications are no longer supplied.</li> </ul> | <p>Check the power drawn by the equipment and disconnect any non-priority devices.</p>  |
| LED (14) flashes.                      | <p>A battery fault was detected during the automatic battery test.</p>  | <ul style="list-style-type: none"> <li>▶ Connect that the battery connector is fully pushed in.</li> <li>▶ Replace battery module (see the Maintenance section).</li> </ul> |

### Troubleshooting requiring MGE UPS SYSTEMS after-sales support

| Indication   | Signification   | Correction                                      |
|--|---|---|
| LED (13) flashes and the buzzer sounds continuously. | <p>UPS electronics have detected a UPS fault. Depending on the UPS personalisation parameters (see section 3.4), there are two possibilities:</p> <ul style="list-style-type: none"> <li>▶ the equipment connected to the UPS continues to be supplied, but directly from the AC-power source (via the automatic bypass (LED (20) ON);</li> <li>▶ the connected equipment is no longer supplied.</li> </ul> <div style="border: 1px solid black; padding: 5px; display: inline-block; margin-top: 10px;"> <p> The equipment connected to the UPS is no longer protected.</p> </div> | <p>Call the after-sales support department.</p> |

## 4. Maintenance

### 4.2 Replacement of the battery module



#### Safety rules:

Batteries constitute a danger (electrical shock, burns). The short-circuit current may be very high. Precautions must be taken for all handling:

- ▶ remove all watches, rings, bracelets and any other metal objects;
- ▶ use tools with insulated handles.

#### Tower model

##### Removal of battery module

- (A) - Press to open door.
- (B) - Slide the door open and remove it.
- (C) (D) (E) - Procedure to remove the protective cover.
- (F) - Disconnect the battery module.
- (G) - Remove the battery module.

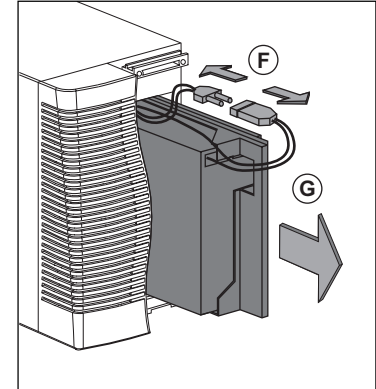
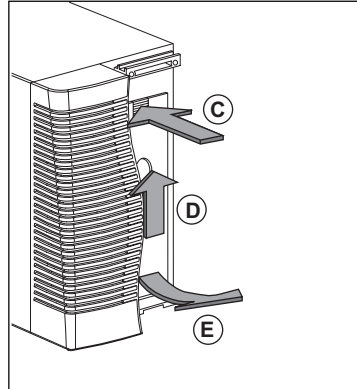
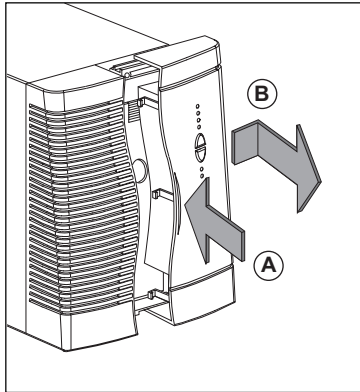

##### Reinstallation of the battery module

Carry out the above operation in reverse order.



▶ To maintain an identical level of performance and safety, use a battery module identical to that previously mounted in the UPS.

▶ Press the two parts of the battery connector tightly together to ensure proper connection.

### Rack model

#### Removal of battery module

- (A) - Remove the two screws securing the door.
- (B) - Slide the door open and remove it.
- (C) - Unscrew the bar that holds the battery module in place.
- (D) - Remove the bar.
- (E) - Disconnect the battery module.
- (F) - Remove the battery module.

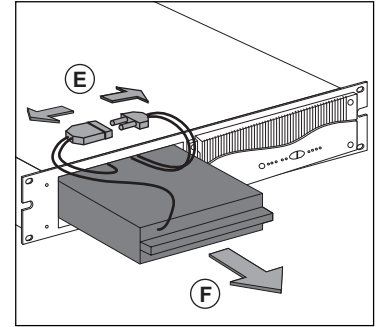
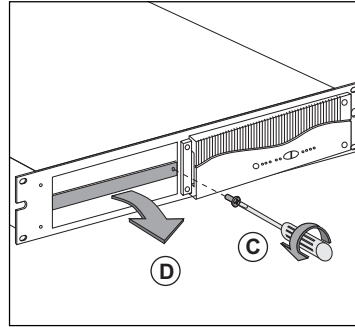
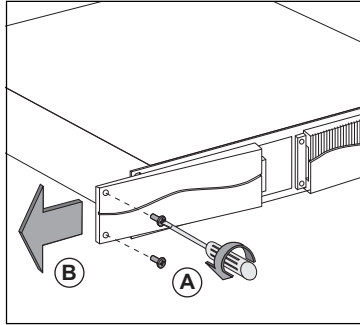

#### Reinstallation of the battery module

Carry out the above operation in reverse order.



- ▶ To maintain an identical level of performance and safety, use a battery module identical to that previously mounted in the UPS.
- ▶ Press the two parts of the battery connector tightly together to ensure proper connection.



## 5. Environment

**This product has been designed to respect the environment:**

It does not contain CFCs or HCFCs.

**UPS recycling at the end of service life:**

MGE UPS SYSTEMS undertakes to recycle, by certified companies and in compliance with all applicable regulations, all UPS products recovered at the end of their service life (contact your MGE branch office).

**Packing:**

UPS packing materials must be recycled in compliance with all applicable regulations.

**Warning:**

This product contains lead-acid batteries. Lead is a dangerous substance for the environment if it is not properly recycled by specialised companies.

**Web site:** [www.mgeups.com](http://www.mgeups.com)



## 6.1 Technical characteristics

### Simplified diagram

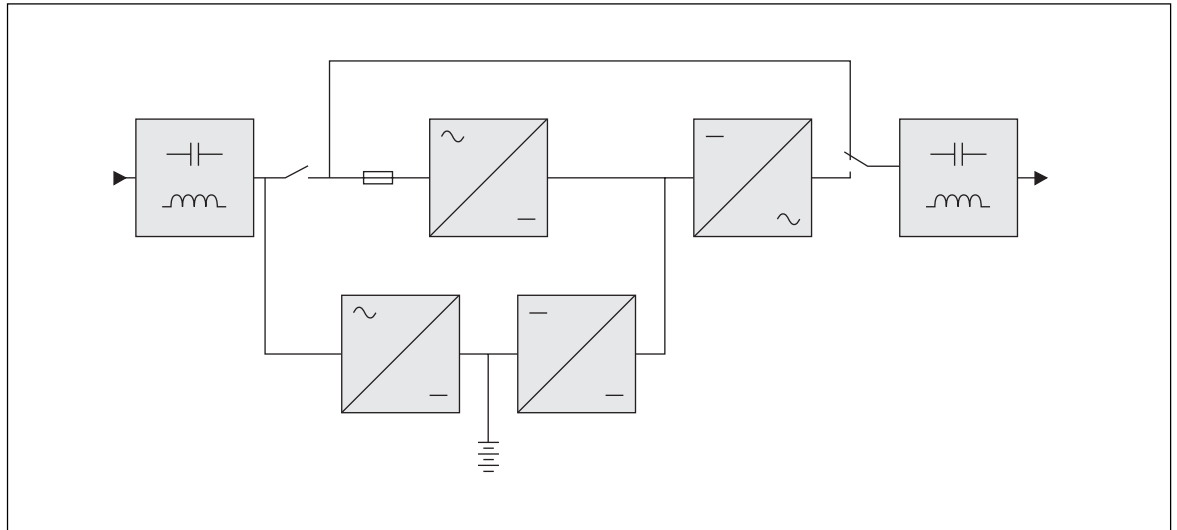

### Operating conditions

Relative humidity: 20 to 90% without condensation.

Temperature: 0 to 40° C.

# 6. Appendices

## 6.2 Glossary

|   |  |
|---|--|
| <b>Authorised voltage range for transfer to bypass if fault or overload</b> | Upper and lower voltage thresholds within which the UPS can operate on the automatic bypass in the event of a UPS fault or overload.   |
| <b>Automatic bypass</b>   | Automatic switch controlled by the UPS, used to connect the equipment directly to the AC-power source in the event of a UPS failure or an overload.  |
| <b>Automatic start following return of AC input power</b>                   | This function automatically starts the UPS when AC input power returns following shutdown at the end of the battery backup time. It can be enabled or disabled.  |
| <b>Backup time</b>  | Time that the connected equipment can operate on battery power.  |
| <b>Bargraph</b>   | Device on the front panel indicating the percent remaining backup time or the percent load.  |
| <b>Battery test</b>   | Internal UPS test on battery status.   |
| <b>Dialog box</b>   | A window in a computer program displayed for selection by the user of various options and parameter settings.  |
| <b>Double conversion</b>  | The power supplied to the connected equipment is completely regenerated by continuous double conversion, i.e. the AC power from the AC-power source is rectified (AC - DC), then converted back (DC - AC) to AC power. |
| <b>Equipment</b>  | Devices or systems connected to the UPS output.  |
| <b>Forced shutdown</b>  | Ten-second interruption in the supply of power to the connected equipment following a system shutdown, even if AC input power returns during the interruption period.  |
| <b>Percent load</b>   | Ratio between the power drawn by the connected equipment and the total power that the UPS can supply.  |
| <b>Personalisation</b>  | A number of UPS functions can be modified using the «UPS Driver» software to better meet the user's needs.   |
| <b>Programmable outlets</b>   | Outlets that can be automatically shed during operation on battery power (a shedding time delay may be programmed using Solution-Pac software).  |
| <b>Start on battery power</b>   | This function makes it possible to energise the connected equipment even when AC input power is not available (operation exclusively on battery power).  |
| <b>UPS</b>  | Uninterruptible Power Supply   |
| <b>UPS ON / OFF via software</b>  | It is possible to enable or disable use of UPS ON / OFF controls by the computer-system protection software.   |

## 6.3 Index

### A

|                           |    |
|---------------------------|----|
| AC power                  |    |
| Failure .....             | 18 |
| Frequency tolerance ..... | 20 |
| Return .....              | 18 |
| Automatic start .....     | 19 |

### B

|                                 |          |
|---------------------------------|----------|
| Bargraph .....                  | 10-17    |
| Battery                         |          |
| Battery test .....              | 19       |
| End of backup time .....        | 18       |
| Fault .....                     | 10-17    |
| Handling precautions .....      | 3        |
| Low-battery warning .....       | 19       |
| Recycling .....                 | 3-24     |
| Replacement .....               | 22-23    |
| Transfer to battery power ..... | 18       |
| Buttons .....                   | 8-9-10   |
| Buzzer .....                    | 17-18    |
| Bypass                          |          |
| Automatic bypass .....          | 10-20-21 |

### C

|                                  |           |
|----------------------------------|-----------|
| Communication .....              | 8-9-14-15 |
| Connection                       |           |
| Additional battery module .....  | 8-9       |
| Communications card .....        | 14        |
| RS 232 communications port ..... | 14        |
| USB communications port .....    | 14        |

### D

|                  |   |
|------------------|---|
| Dimensions ..... | 7 |
|------------------|---|

### E

|                     |        |
|---------------------|--------|
| Environnement ..... | 2-3-24 |
|---------------------|--------|

### F

|                   |          |
|-------------------|----------|
| Fault (UPS) ..... | 10-17-21 |
|-------------------|----------|

### L

|                 |        |
|-----------------|--------|
| LEDs .....      | 8-9-10 |
| Lamp test ..... | 10     |

### M

|                    |    |
|--------------------|----|
| Mode               |    |
| ON LINE mode ..... | 10 |

### O

|                |          |
|----------------|----------|
| Overload ..... | 10-20-21 |
|----------------|----------|

### S

|                                 |       |
|---------------------------------|-------|
| Safety .....                    | 3     |
| Shutdown                        |       |
| Buzzer .....                    | 10-18 |
| Forced shutdown .....           | 19    |
| UPS ON / OFF via software ..... | 19    |
| UPS shutdown .....              | 10-20 |
| Sleep mode .....                | 18-19 |
| Automatic restart .....         | 19-20 |
| Software                        |       |
| UPS Driver .....                | 19    |
| Start-up .....                  | 17    |

### T

|                                 |    |
|---------------------------------|----|
| Technical characteristics ..... | 25 |
| Temperature                     |    |
| Excessive ambient temp. ....    | 25 |
| Transfer (forced) .....         | 10 |

### U

|                   |          |
|-------------------|----------|
| UPS Driver .....  | 19       |
| UPS fault .....   | 10-17-20 |
| UPS storage ..... | 3        |

### W

|                |   |
|----------------|---|
| Web site ..... | 2 |
| Weight .....   | 7 |

